

FUNDAMENTALS OF STRUCTURAL ANALYSIS

5th Edition

Kenneth M. Leet, Chia-Ming Uang, Joel T. Lanning, and Anne M. Gilbert

SOLUTIONS MANUAL

CHAPTER 3: STATICS OF STRUCTURES - REACTIONS

P3.1. Determine the reactions for the structure.

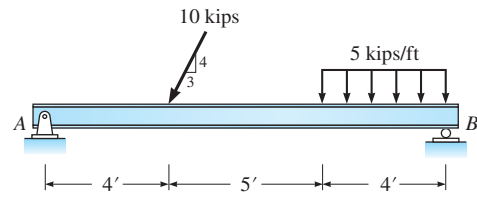

P3.1

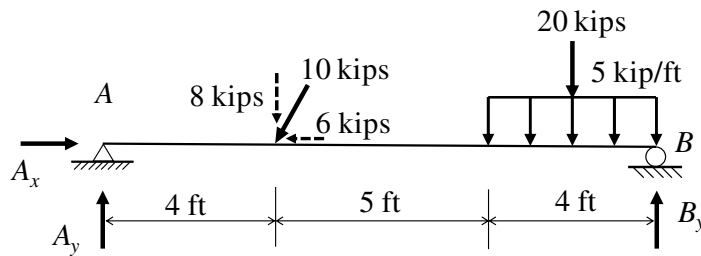

$$\overset{+}{\curvearrowright} \Sigma M_A = 0;$$

$$8^k(4') + 20^k(11') - B_y(13') = 0$$

$$\boxed{B_y = 19.38 \text{ kips } \uparrow}$$

$$\overset{++}{\Sigma} F_x = 0;$$

$$A_x - 6^k = 0$$

$$\boxed{A_x = 6^k \rightarrow}$$

$$\overset{+}{\uparrow} \Sigma F_y = 0;$$

$$A_y - 8^k - 20^k + 19.38^k = 0$$

$$\boxed{A_y = 8.62^k \uparrow}$$

P3.2. Determine the reactions for the structure.

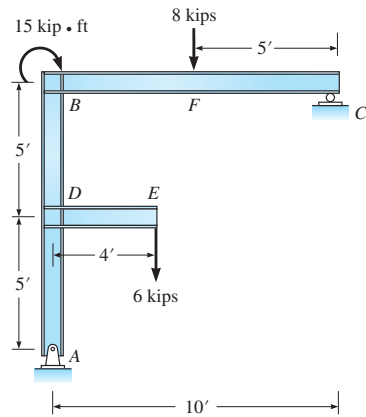

P3.2

$$\sum M_A = 0;$$

$$15^{\text{ft} \cdot \text{k}} + 8^{\text{k}}(5') + 6^{\text{k}}(4') - C_y(10') = 0$$

$$C_y = 8.5^{\text{k}} \uparrow$$

$$+\uparrow \sum F_y = 0;$$

$$-8^{\text{k}} - 6^{\text{k}} + 8.5^{\text{k}} + A_y = 0$$

$$A_y = 5.5^{\text{k}} \uparrow$$

$$\sum F_x = 0;$$

$$A_x = 0$$

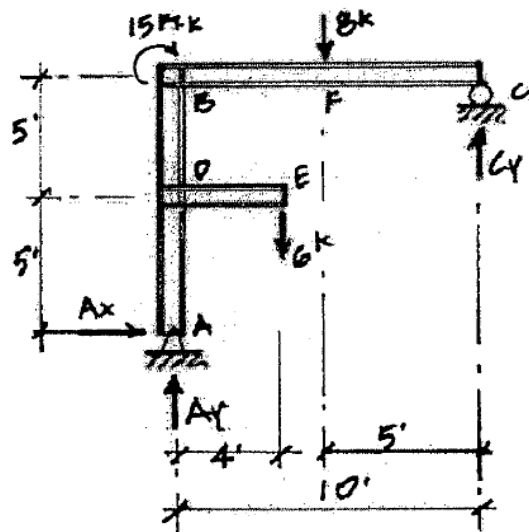

P3.6. Determine the reactions for the structure.

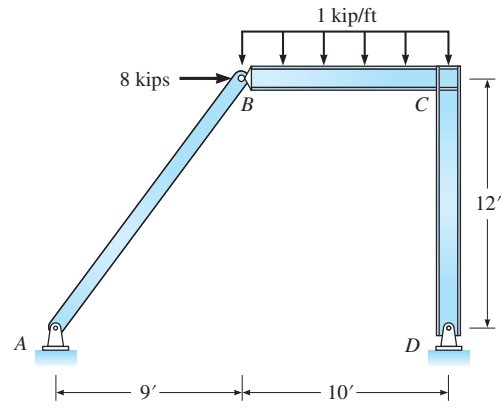

P3.6

$$\overset{+}{\curvearrowright} \Sigma M_A = 0; \quad 8 \times 12 + 10 \times 14 - D_y(19) = 0$$

$$D_y = 12.42 \text{ kips } \uparrow$$

$$\overset{+}{\uparrow} \Sigma F_y = 0; \quad \frac{4}{5}(-R_A) + 12.42 - 10 = 0$$

$$R_A = 3.025 \text{ kips } \swarrow$$

$$\overset{+}{\rightarrow} \Sigma F_x = 0; \quad \frac{3}{5}(-3.025) - D_x + 8 = 0$$

$$D_x = 6.185 \text{ kips } \leftarrow$$

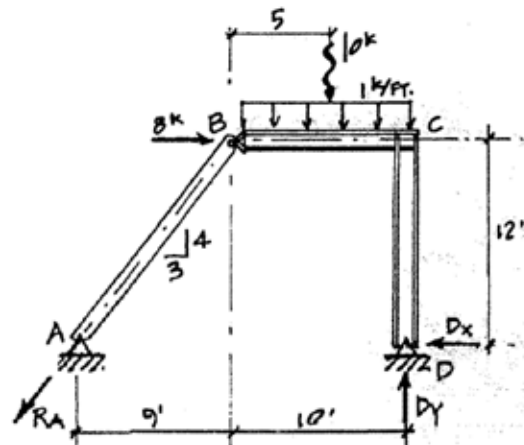

P3.8. Determine the reactions at all supports and the force transmitted through the hinge at B.

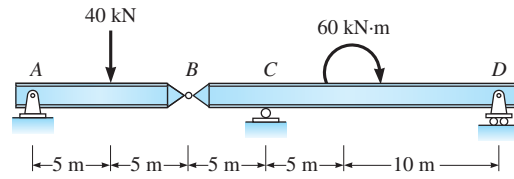

P3.8

FBD "AB"

$$A_y = F_{by} = 20 \text{ kN}$$

B_y Symmetry.

FBD "BCD"

$$\sum M_d = 0;$$

$$-20^{\text{kN}}(5\text{m}) + 60 \text{ kN} + D_y(15\text{m}) = 0 \quad D_y = 2.67 \text{ kN} \downarrow$$

$$+\uparrow \sum F_y = 0; \quad -20 + C_y - 2.67 = 0 \quad C_y = 22.67 \text{ kN} \uparrow$$

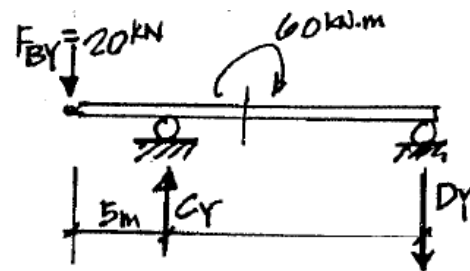
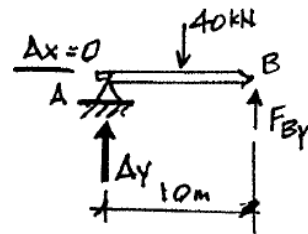

Entire Structure

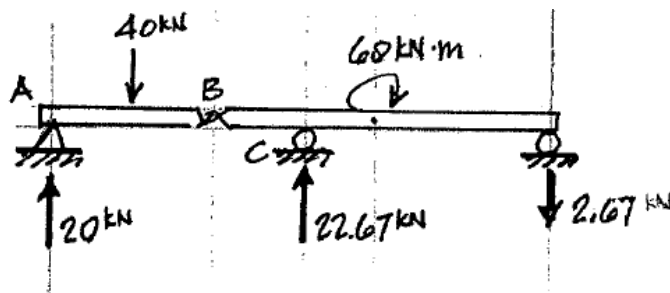

P3.10. Determine the reactions for the structure. All dimensions are measured from the centerlines of members.

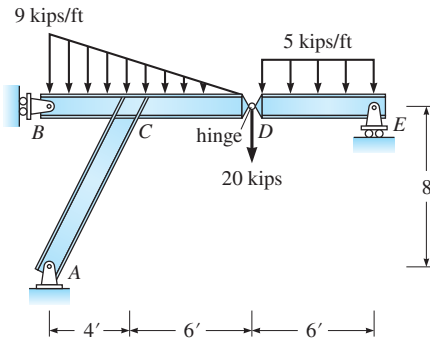

P3.10

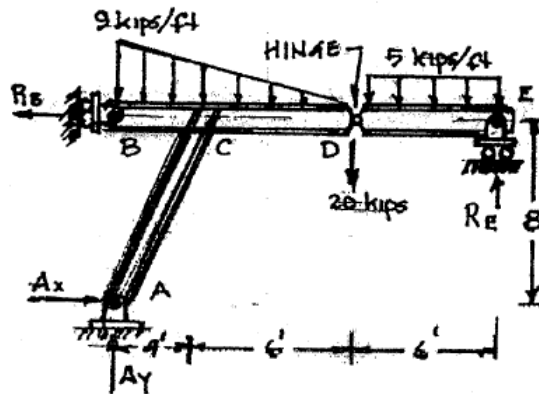

Freebody Diagram Right of Hinge D:

$$\overset{\curvearrowright}{\Sigma} M_d = 0; \quad 30^k(3') - R_e 6' = 0$$

$$\boxed{R_e = 15 \text{ kips} \uparrow}$$

$$\uparrow \Sigma F_y = 0; \quad D_y - 30^k + R_e - 15^k = 0$$

$$\boxed{D_y = 15 \text{ kips} \uparrow}$$

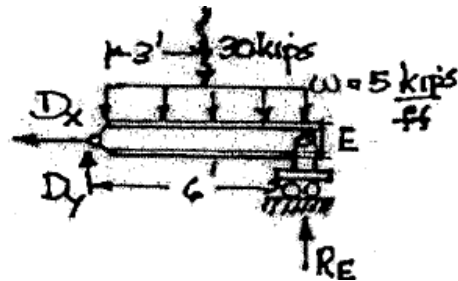

Freebody Diagram Left of Hinge:

$$\overset{\curvearrowright}{\Sigma} M_A = 0; \quad -R_b 8' + 45^k \left(\frac{10'}{3} \right) + 35^k(10') = 0$$

$$\boxed{R_b = 62.5 \text{ kips} \leftarrow}$$

$$\rightarrow \Sigma F_x = 0; \quad A_x - R_b = 0$$

$$\boxed{A_x = 62.5 \text{ kips} \rightarrow}$$

$$\uparrow \Sigma F_y = 0; \quad A_y - 45^k - 15^k - 20^k = 0$$

$$\boxed{A_y = 80 \text{ kips} \uparrow}$$

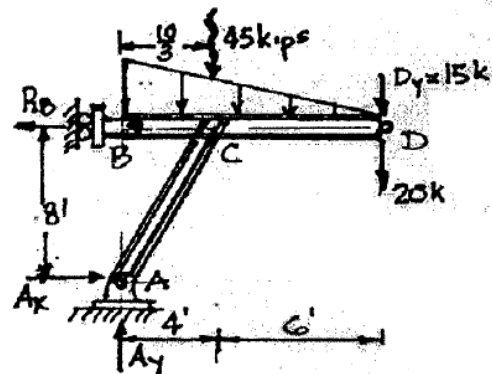

P3.14. Determine the reactions at all supports and the force transmitted through the hinge at C.

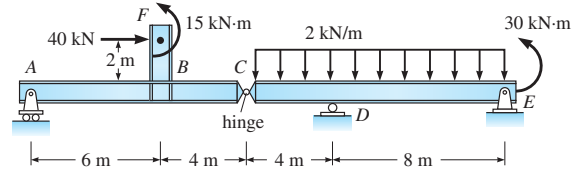

P3.14

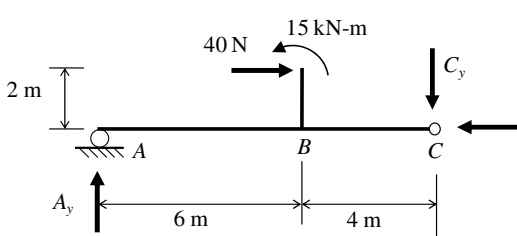

Figure (a)

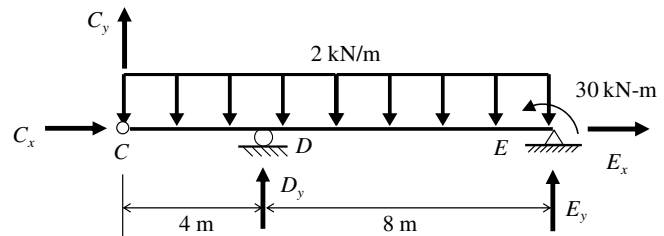

Figure (b)

Figure (a):

$$\Sigma M_A = -15 + 2(40) + 10C_y = 0$$

$$C_y = -6.5 \text{ kips } \uparrow$$

$$\Sigma F_y = A_y - C_y = 0$$

$$A_y = -6.5 \text{ kips } \downarrow$$

$$\Sigma F_x = 40 - C_x = 0$$

$$C_x = 40 \text{ kips } \leftarrow$$

Figure (b):

$$\Sigma M_e = -30 - 6(2)(12) + 8D_y + 12C_y = 0$$

$$D_y = 31.5 \text{ kips } \uparrow$$

$$\Sigma F_y = D_y + C_y - 12(2) + E_y = 0$$

$$E_y = -1 \text{ kips } \downarrow$$

$$\Sigma F_x = C_x + E_x = 0$$

$$E_x = -40 \text{ kips } \leftarrow$$

P3.26. Compute the reactions at supports A, E, and F.

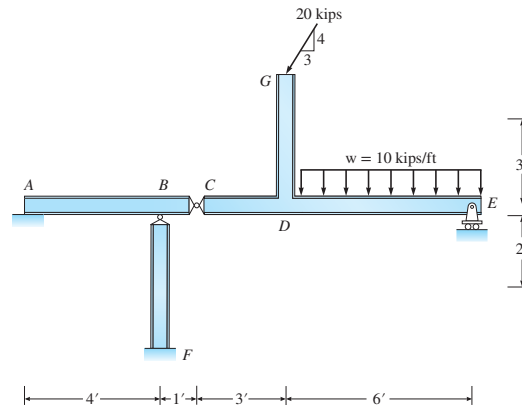

P3.26

Figure (b):

$$\Sigma M_C = -20\left(\frac{3}{5}\right)3 + 20\left(\frac{4}{5}\right)3 + 10(6)6 - 9E_y = 0$$

$$E_y = 41.33 \text{ kips } \uparrow$$

$$\Sigma F_y = E_y - 6(10) - 20\left(\frac{4}{5}\right) + C_y = 0$$

$$C_y = 34.67 \text{ kips}$$

$$\Sigma F_x = C_x - 20\left(\frac{3}{5}\right) = 0$$

$$C_x = 12 \text{ kips}$$

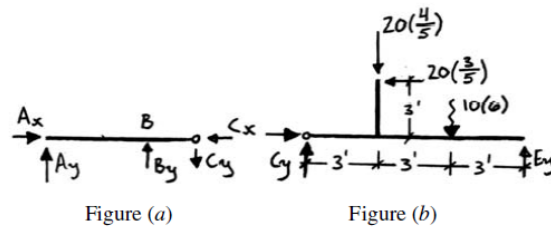

Figure (a)

Figure (b)

Figure (a):

$$\Sigma M_A = -4B_y + C_y(5) = 0$$

$$B_y = 43.33 \text{ kips } \uparrow$$

$$\Sigma F_y = A_y + B_y - C_y = 0$$

$$A_y = -8.66 \text{ kips } \downarrow$$

$$\Sigma F_x = A_x - C_x = 0$$

$$A_x = 12 \text{ kips } \rightarrow$$

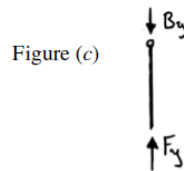

Figure (c)

Figure (c):

$$\Sigma F_y = F_y - B_y = 0$$

$$F_y = 43.33 \text{ kips } \uparrow$$